



zogics | FLOORING

ROLLED RUBBER FLOORING

PRODUCT BROCHURE



ZOGICS ROLLED RUBBER FLOORING

Zogics Rolled Rubber Flooring is a best seller for a reason. This dense and resilient flooring allows for maximum comfort and impact absorption. Customize by color, measurements, and marketing such as custom logos.

All Zogics Flooring is made of 100% recycled rubber. Contains low VOCs (that rubber smell) and proudly made in the USA.



WHY ZOGICS RUBBER FLOORING?

Zogics is your partner for custom rolled rubber flooring. We can help you design the custom flooring solution for your needs and your budget. Our experts will walk you through every step, from ideation to design to installation. Each facility receives a custom design. Leave us the heavy lifting so you can get back to what you do best.



Little to No Odor
(Lowest VOCs)



Quickest Lead
Time & Easiest
Quoting



Full Design Staff
for Layout



Custom Branding
Available



100% Recycled
Rubber



5-Year
100% Warranty

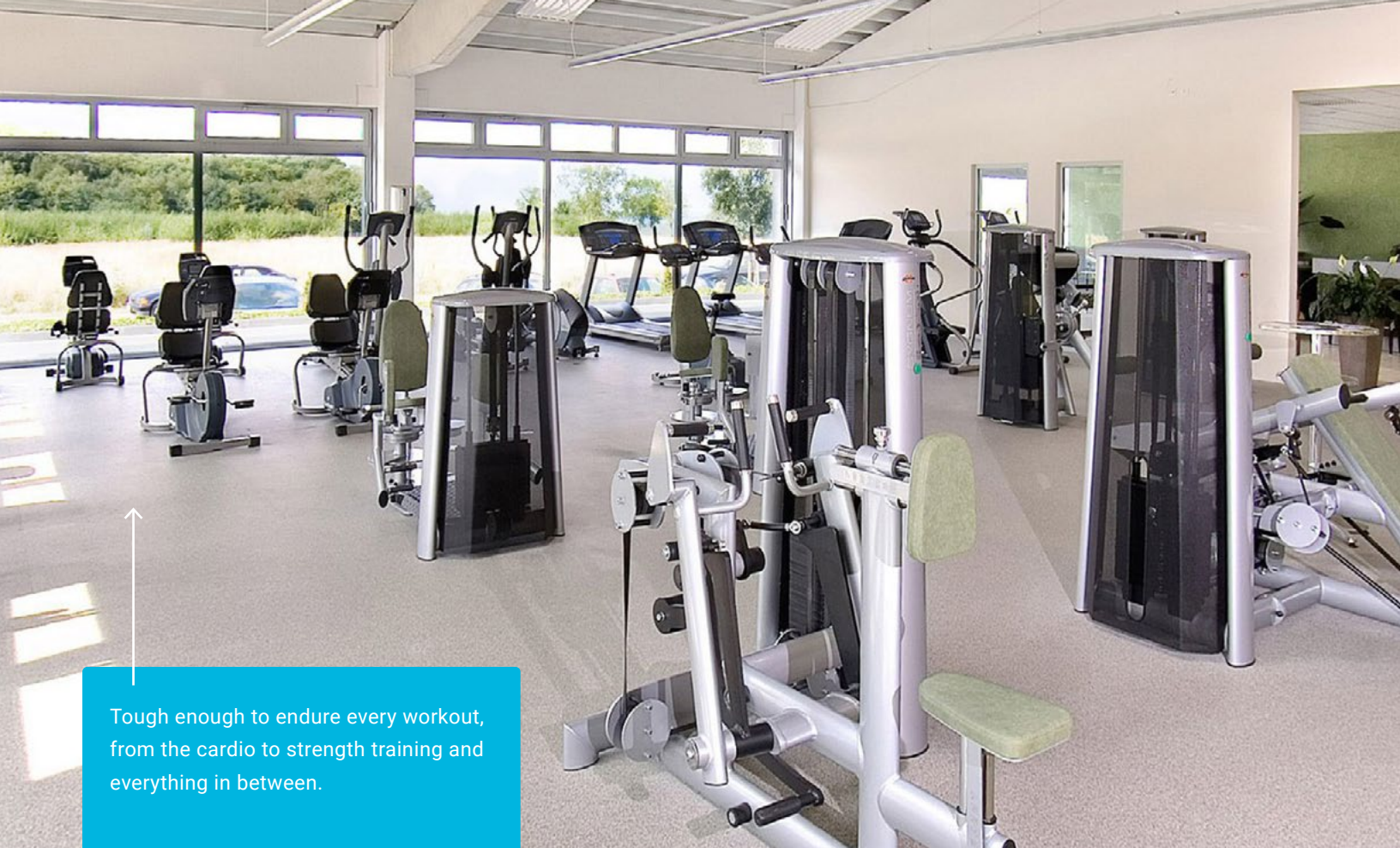

Tough enough to endure every workout, from the cardio to strength training and everything in between.

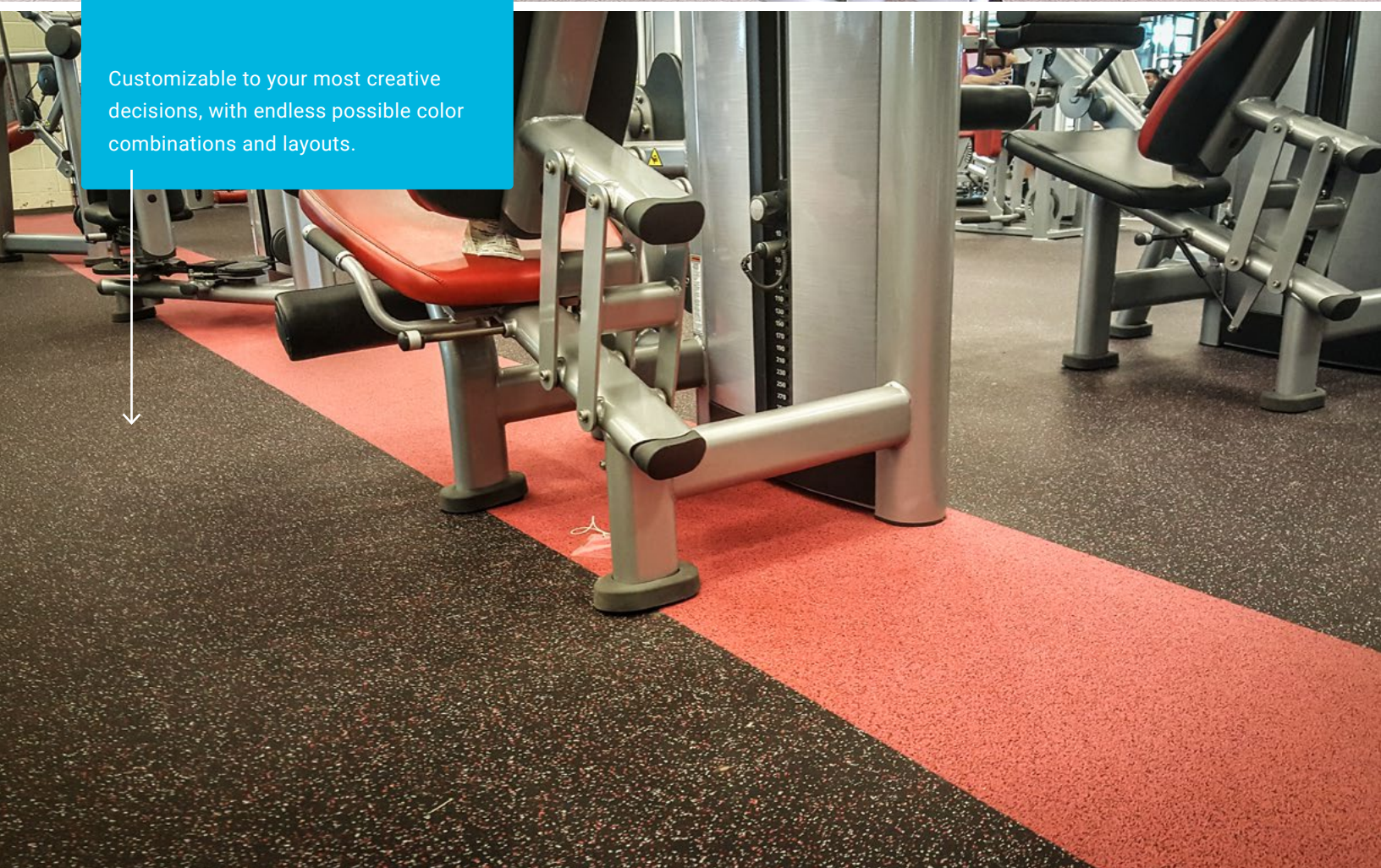

Customizable to your most creative decisions, with endless possible color combinations and layouts.

COLORS

Match your facility's look and design with a wide range of color options. Our rolled rubber flooring is available in two color sets, Core and Flex:

CORE

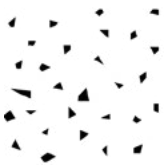

Core colors are solid and lightly patterned flecks colors. The color fleck is embedded throughout the entire thickness in rolled rubber flooring.

FLEX

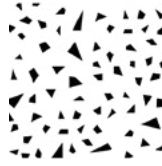

Flex colors adds more flecks into the color mix. These colors, when viewed as a large floor, read as the most patterned rubber flooring.



Core Black

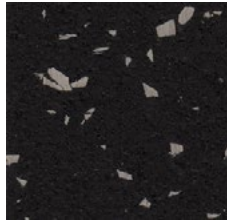

Core Gray

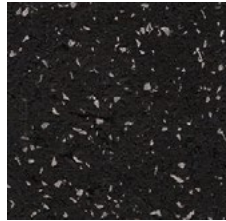

Core Iron

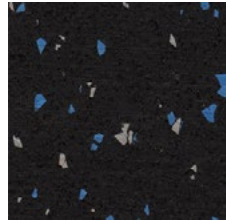

Core Smoke

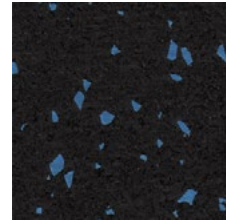

Core Cobalt

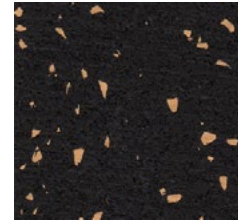

Core Sand



Core Volcano

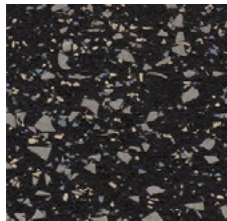

Flex Slate

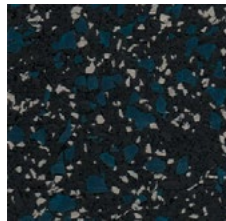

Flex Mineral

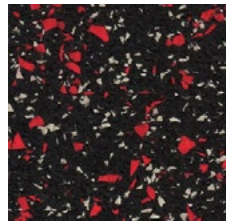

Flex Flame



Flex Buff



CUSTOM BRANDING

Using precision water-jet cutting, we make it easy to incorporate your facility logo, branding, or messaging into your flooring. Each logo is manufactured out of the same recycled rubber and is installed to create a seamless surface for your members. Get in touch if you're interested in custom branding your rubber flooring.

3 THICKNESS OPTIONS

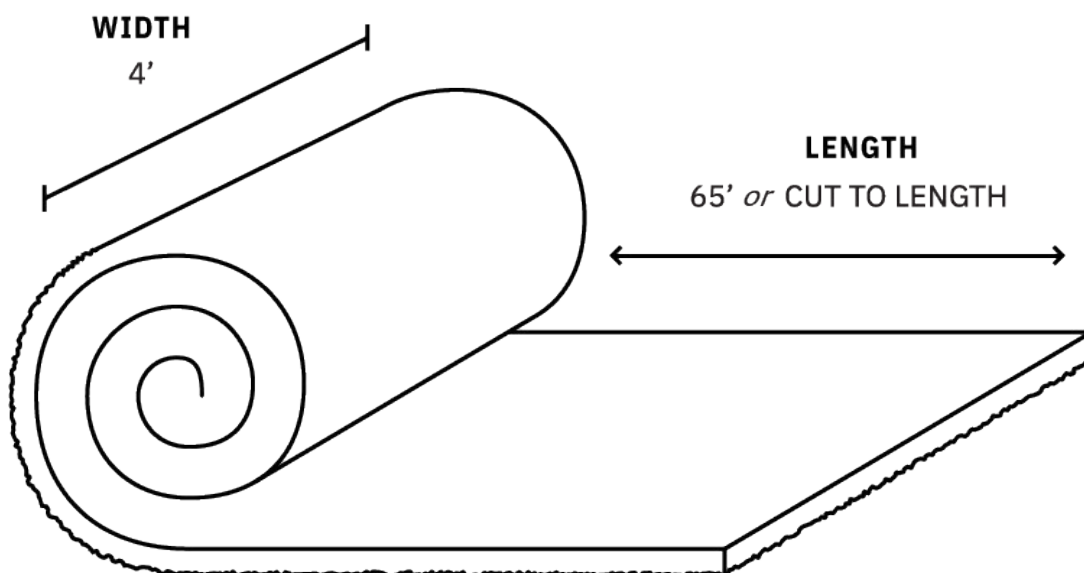
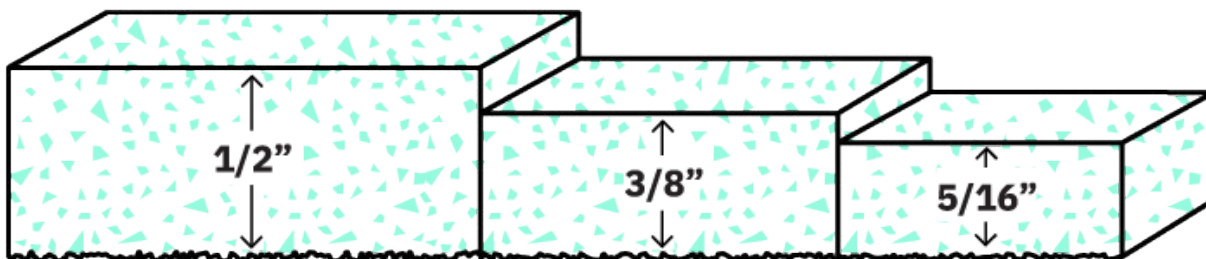

FEATURES

- Slip Resistant (wet or dry)
 - Economic & Low Maintenance
 - Easy Installation
 - Seamless Appearance
 - 5-Year Warranty
 - Ability to Add Logo or Branding
 - Made in the USA
- (minimums apply)

SPECIFICATIONS

- **Thickness:** 1/2", 3/8", 5/16"
 - **Roll Width:** 4' (48')
 - **Roll Length:** Standard 65',
Custom cuts available at no charge
- NOTE: Minimum Order of 100 sq/ft*

MARKET APPLICATIONS

- Fitness Flooring
- Health Clubs
- Indoor Recreation
- Locker Rooms
- Functional Training
- Weight Rooms

TECHNICAL CHARACTERISTICS

PERFORMANCE	STANDARD	5/16" THICKNESS	5/16" THICKNESS	5/16" THICKNESS
Roll Construction		Non-laminated, single ply	Non-laminated, single ply	Non-laminated, single ply
Roll Width		48"	48"	48"
Roll Length		65' (custom cuts available)	65' (custom cuts available)	50' (custom cuts available)
Weight		1.75 lb per sq/ft	2.05 lb per sq/ft	2.73 lb per sq/ft
Tolerances		Thickness: +.5mm -.5mm	Thickness: +.5mm -.5mm	Thickness: +.5mm -.5mm
		Width: +1/2" - 0	Width: +1/2" - 0	Width: +1/2" - 0
Tensile Strength	ASTM D412	>220 PSI	>220 PSI	
Tear Strength	ASTM D624	80 Pli. Min.	80 Pli. Min.	80 Pli. Min.
Flexibility	ASTM F137	Pass	Pass	Pass
Hardness (Shore A)	ASTM D2240	63 +/-5	63 +/-5	63 +/-5
Coefficient of Friction	ASTM D2047	Dry = 1.10/Wet = 0.95	Dry = 1.10/Wet = 0.95	Dry = 1.10/Wet = 0.95
Pill Flammability	ASTM F1514	Pass	Pass	Pass
Resistance to Light	ASTM F1515	Pass	Pass	Pass
Resistance to Chemicals	ASTM F925	No Change	No Change	No Change
Resistance to Heat	ASTM F4060	Pass	Pass	Pass
Vertical Rebound	ASTM F2117	99.75%	99.50%	99%



Still have questions?
We love to help!