

# Installation Manual

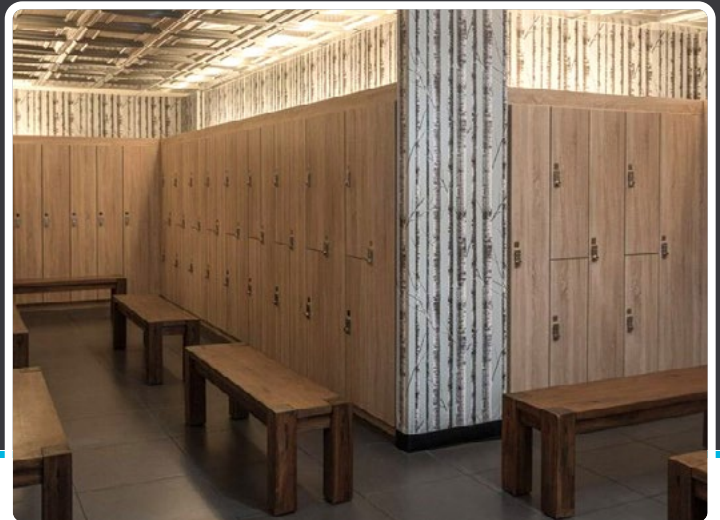

## 1. Before Receiving Lockers

- 1.1 – Locker Layout
- 1.2 – Base Construction

## 2. Receiving & Unloading

- 2.1 – Delivery & Logistics
- 2.2 – Receiving Lockers
- 2.3 – Handling
- 2.4 – Hardware Kit Contents

## 3. Installing Lockers

- 3.1 – Standard Locker Installation

## 4. Installing Panels

- 4.1 – End Panels
- 4.2 – Filler Panels

## 5. Finishing Touches

- 5.1 – Number Discs
- 5.2 – Hinge Adjustment
- 5.3 – Cleaning & Maintenance

### Tool List & Required Materials

- Drill
- Level
- Tape Measure
- Hammer
- Phillips Screwdriver
- Dolly
- Cleaning Solution
- Stud Finder
- Circular Saw
- Wood Glue
- Silicon Adhesive (not included; found at local hardware store)
- Locker Base – 2x4 Lumber
- Locker Base – 1/2" Plywood
- Locker Base – Wood Screws 1"

### Installation Overview

1. Room dimensions are verified and plan is created showing locations and dimensions of all room elements to determine space requirements.
2. Base is built, set in place, leveled and secured.
3. Lockers are unloaded, hardware kit located in locker with yellow tape.
4. Lockers are set in place, level and plumb, secured to base, wall and bolted to each other.
5. Trim is installed: crown, finished base trim or valance.
6. Doors checked for function, swing, lock operation and adjusted as necessary.
7. Number discs and name plates, as appropriate are put on.

## 1. Before Receiving Lockers

### 1.1 Locker Layout

Before receiving your lockers, you need to plan for how they will be placed within your space. Here are some notes to keep in mind:

- Locker banks should be centered on each wall with a minimum of 4" space between the last locker and the wall on each side so that the locker doors can function properly.
- Filler panels should be mounted to fill spaces between lockers and walls.
- Peninsulas of lockers, or other instances where the last locker is exposed to the room, should be finished with an end panel.

### 1.2 Base Construction

To determine base size subtract 3 inches from locker depth to create toe kick space. Cross members need to be added approximately every 24 inches, on center.

- Cut pressure treated 2x4's\* and use 1" wood screws to build frame.
- Frames must be nailed or screwed to the back wall and shimmed to level (front to back/ end to end).
- Attach 1/2" plywood on top edge of frame to create decking for lockers.
- Level the base: front to back, side to side and plumb, rather than leveling each locker.
- Curb to be 4" tall

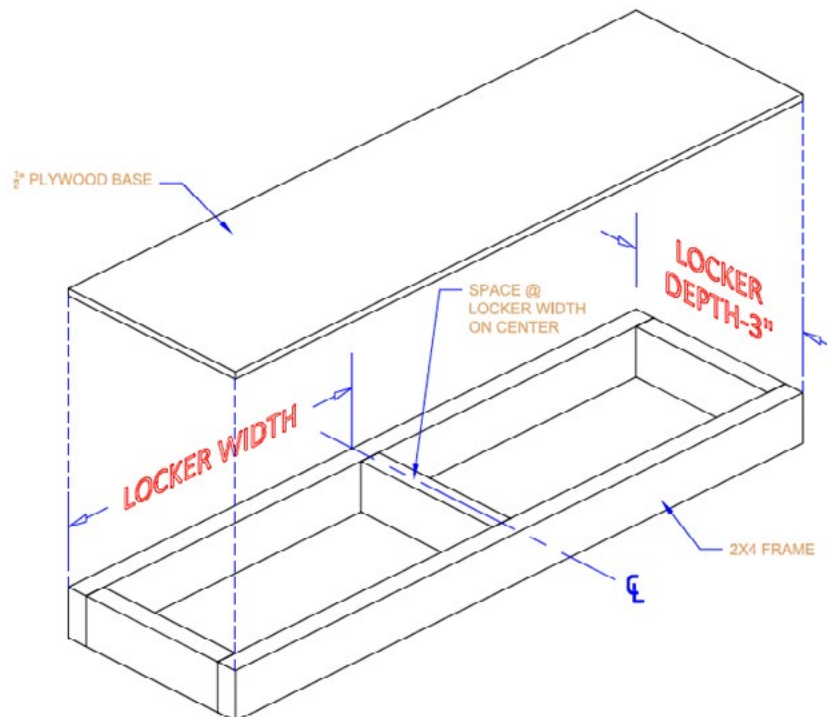

\*Size may vary based on project. See drawings for project specific details.

## **2. Receiving & Unloading**

### **2.1 Delivery & Logistics**

Lockers will be shipped either floor loaded or palletized, depending upon the size of the project. Lockers will be delivered via truck with 53 foot trailer, please ensure in advance the receiving area can accommodate a full-sized truck or if special considerations are required.

- Each locker is shipped as a fully assembled unit and typically is wrapped and strapped inside the trucks. Please take care when releasing straps in case lockers have shifted in transit.
- Flat material including end panels and filler panels are sometimes strapped to the sides of the truck interior for shipment. Please take care when releasing the straps so that the panels do not slide to the floor and become damaged.
- Note: Chips in laminate at back and sides are unavoidable and will not be visible once lockers are attached together.

### **2.2 Receiving Lockers**

When you receive your order please follow the instructions below; Zogics will not be responsible for damaged items that have a Clear Delivery Receipt from the freight carrier.

- Inspect the shipping packages for any visible damage outside of the cartons. If you find any damages, make time to inspect the contents of the damaged carton.
- Always accept your shipment and make comments on the freight carrier's Delivery Receipt that there was visible damage to the shipping cartons. List the items that are damaged on the Delivery receipt.
- Take photos and keep a copy of the delivery receipt. Any damaged items and packaging must be kept for freight company to inspect if needed.
- If you find that items have been damaged during shipment and you signed the Delivery Receipt as damaged material, contact Zogics at (888) 623-0088.
- Count the number of pallets and cartons and make sure you have the correct number of pallets and cartons as stated on the Delivery Receipt. If you are missing any pallets or cartons, make a note on the Delivery Receipt, Zogics will not be responsible for missing pallets or cartons that were not marked missing on the Delivery Receipt.
- Open each box and verify the material and hardware have not been damaged.
- If the cartons do not appear to be damaged on the outside and you do not open to verify the contents and have signed for a Clear Delivery, Zogics will not be responsible for concealed damage.

#### **Missing Items**

Please notify Zogics within 48 hours of receipt of the materials. Zogics will arrange for ground shipment of any items found to be missing that you have noted on the Delivery Receipt. Any items found to be missing that was not noted on the Delivery Receipt will be the customer's responsibility.

## 2. Receiving & Unloading

### 2.3 Handling Lockers

- Using a dolly or hand truck, unload the locker frames one by one, making sure the back or side of the locker is the only point of contact. Never lean the locker on its door.
- Proceed to move locker with one hand on the unit for stability. Carry lockers directly to the locker area, setting them into approximate position on the base.
- Never drag or push lockers across floor

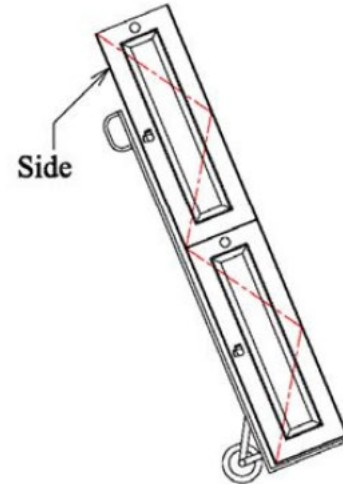

### 2.4 Hardware Kit Contents

- **Male/Female Connector Bolts** - used for connecting lockers together for stability
- **Drywall Screws** - used to connect lockers to walls for added stability; must be counter-sunk into lock body.
- **Cover Caps** - used to conceal holes in locker interiors where screws or bolts have been used.
- **Number Discs**- glued to front of locker door for identification.

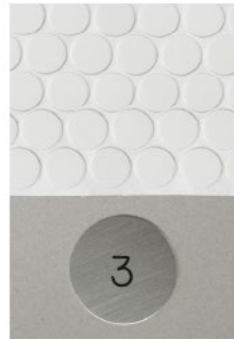

### 3. Installing Lockers

#### 3.1 Standard Locker Installation

- Each locker should be secured to its neighbor using connecting bolts into the pre-drilled holes, four per frame per side.
- Do not over tighten to avoid stripping the female side of the connector or potentially cause the frame to bow at the connection points.
- Lockers should be secured to the wall behind using drywall screws. Lockers on each end should be secured and screws should be placed approximately each 32" apart into wall framing.
- Screws are included in the hardware kit for this purpose, but please make sure that all screws extend a minimum of ½ inch into the supporting surfaces. \*Depending on location and layout, longer screws may be needed.
- Every fourth locker should be connected to the base using drywall screws. At least two screws should be used in the back of the lockers, and optionally, two additional screws can be used in the front as well.

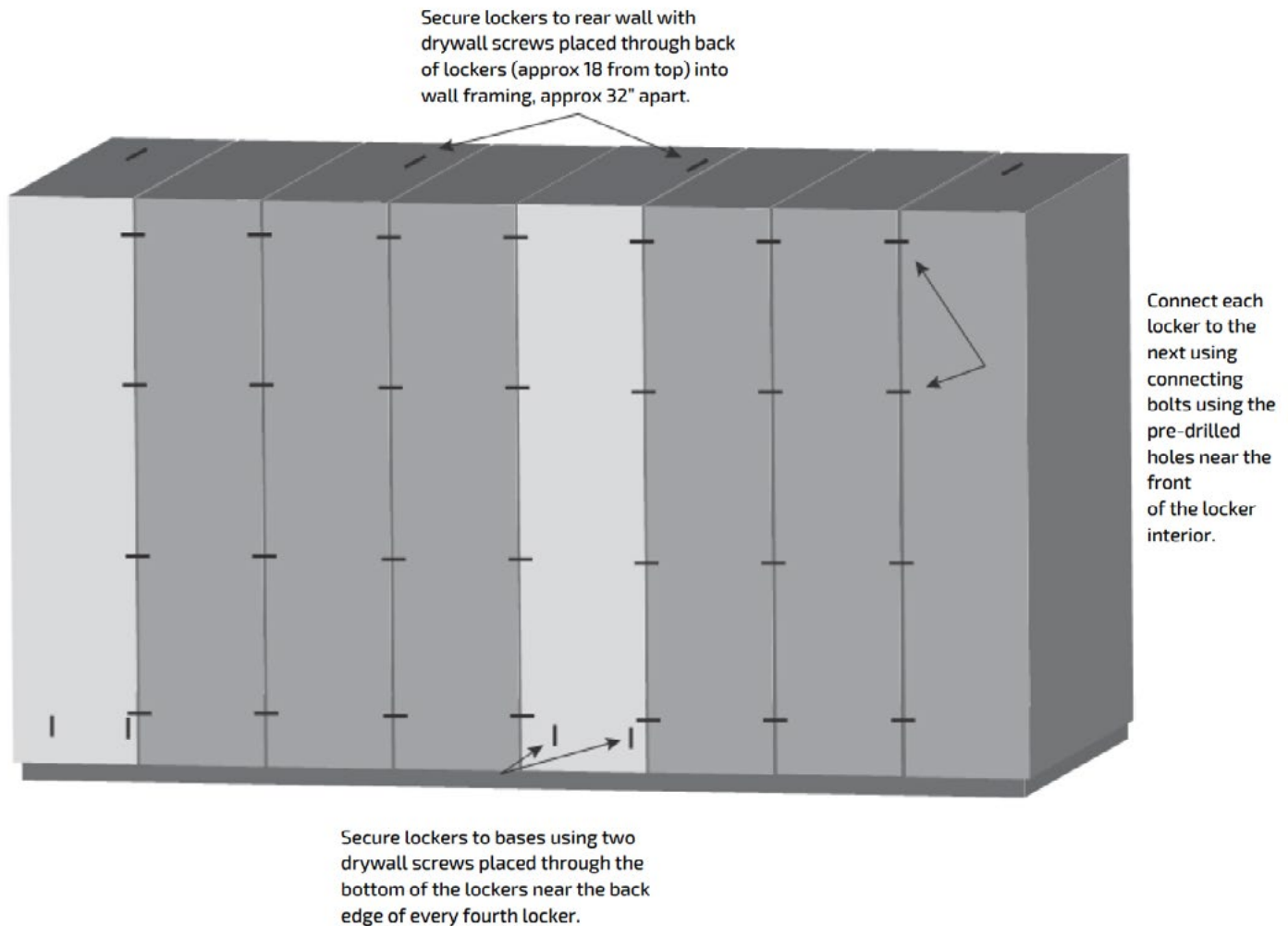

## 4. Installing Panels

### 4.1 End Panels

- End Panels are used to provide a finished side wherever banks of lockers extend into a space. They are built to match the lockers in both finish and style. (No end panels are needed when the bank of lockers is recessed into a wall.)
- End panels are built in either single or double widths, depending on the layout of the room. (Double width panels extend to cover the sides of two lockers, installed back-to-back in a peninsula layout.)

1. Align panel with locker frame, and using drywall screws, drill into end panel through interior of locker. A minimum of 8 screws should be used, aligning horizontally and spaced one inch to the inside, with the pre-drilled holes used to connect lockers to each other.
2. It is recommended to apply a small amount of wood glue to panel before attaching for extra support
3. Cover all holes in locker interior with cover caps.

**NOTES & WARNING:**

- Do not use the pre-drilled connector holes for the end panel attachment.
- When installing either raised panel or flat panel end panels the screw must go into the stile and not the center panel.
- Do not use screws longer than 1" when installing the end panels. Any longer and screw may penetrate the end panel.

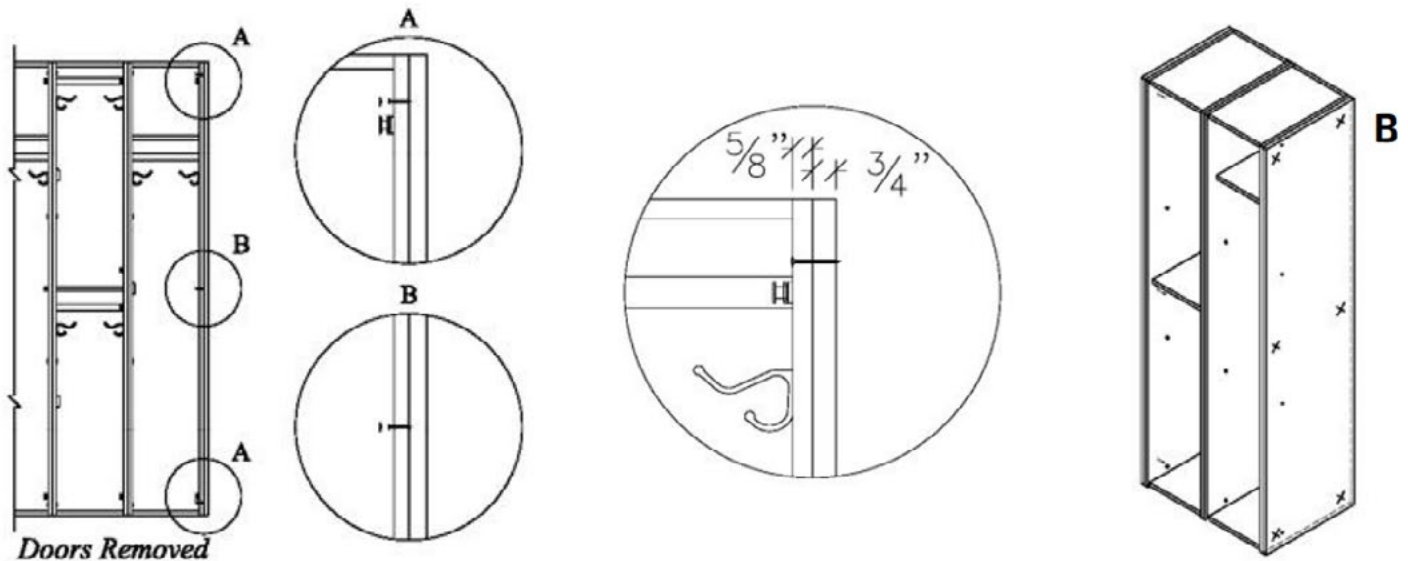

## 4. Installing Panels

### 4.2 Filler Panels

Filler Panels are installed between the end of a bank of lockers and a wall. They cover any blank space for a finished look and also provide enough gap between lockers and walls to allow the locker doors to swing open properly. Filler panels are finished on one side in matching laminate or veneer and are provided in sheets. Installers on site will need to cut the panels to required measurements.

1. If being installed between walls, locker sets should be installed with equal space for filler panels on each side, with a minimum width of 4 inches to allow doors to swing properly.
2. Cut filler panels with a circular saw.
3. Screw through the locker into the thin edge of each panel, using caps on all screw heads. The filler should be attached to the wall as well, using a back-piece if necessary.

#### Inside Corner

Measure and cut your two piece filler. Attach blocking if desired first then the two pieces to each other using a standard butt joint. Insert corner filler into the inside corner. Using screws and pre-drilled holes attach the filler to the frames from the inside of the locker frame. To cover the corner hole, install blocking on the walls and frame below the line of sight. Make a cover, of drywall or plywood, and secure it to the blocking using screws.

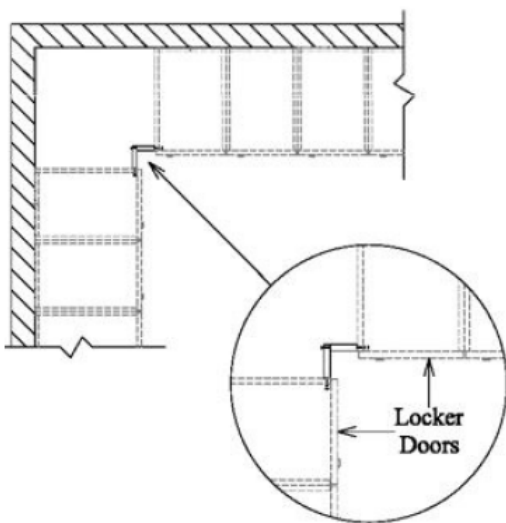

#### Frame to Wall

Measure the distance between the frame and the wall cutting your filler panel to that dimension. Attach mounting blocks to the back of the filler panel so you have a means of attaching the filler to the wall. Use screws to attach to the wall. From the inside of the locker frame attach the filler to the frame

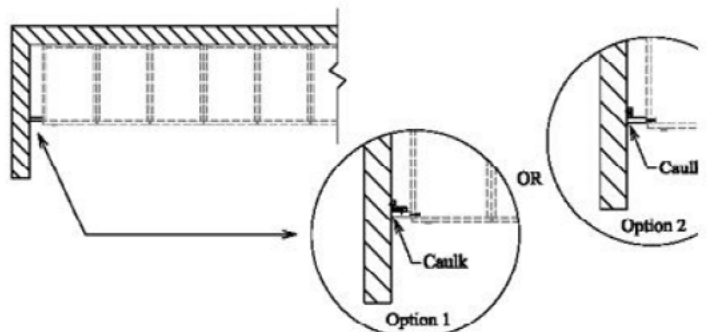

## 5. Finishing Touches

### 5.1 Number Discs & ADA Placards

Each locker door will have some type of identification; which can vary but the most common is a routed recess for a number disc. Number discs are applied in the field as this method is the easiest for the installer. Number discs are found in your hardware kit. **Please note, the silicone adhesive is not included in the hardware kit. A small tube of silicone adhesive can be found at your local hardware store.**

#### Number Disks

- Before starting, review your layout or number plan for the start and sequence. If there is not a number plan start at a door way and go clockwise numbering all lockers.
- Apply a small amount of silicone adhesive, less than a pea size, in each routed disc recess. Press the number disc into the recess. This will adhere the disc to the locker. Make sure the numbers are level before moving on. Do not make any adjustments once the silicone starts to bond and set up. Doing so will stop the adhesion and the number disc will, over time, become detached.

#### ADA Placard

- Apply the same silicone adhesive to the backside of the ADA Placard. Press the placard onto the locker door and use blue painter's tape to hold it in place while the adhesive dries. Once adhesive is dry, remove blue tape.

### 5.2 Hinge Adjustment

- Due to shifting during shipment as well as changes over time, locker hinges may need to be adjusted to maintain optimum function and level doors across rows. We use specialty hinges that can be adjusted in three directions. Please see the diagram below for information.
- Some products utilize soft-close mechanisms integrated into the hinge interior. These function as a small piston that forces the door to close without slamming. These can also be adjusted to control the amount of resistance that they provide.

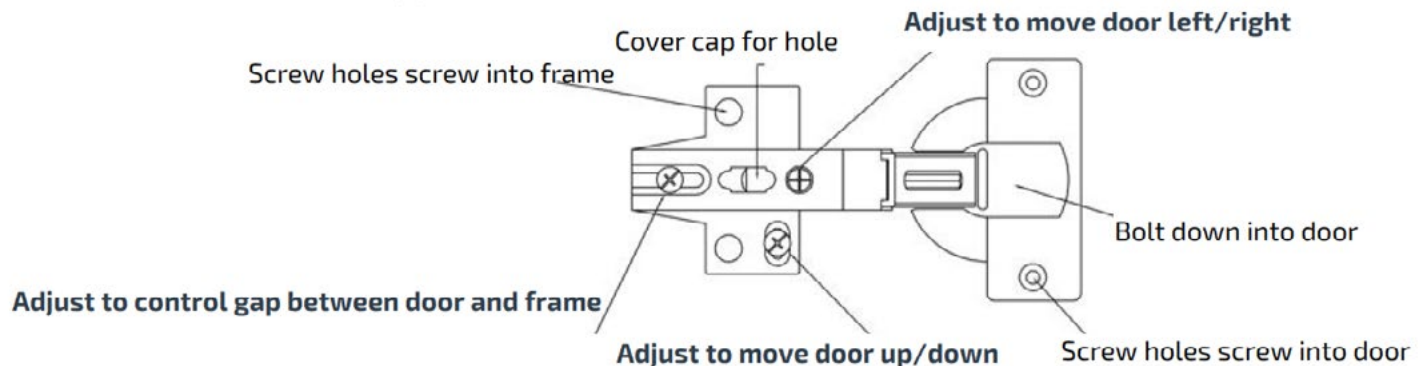

### 5.3 Cleaning & Maintenance

Locker interiors are made from melamine and can be cleaned with a damp cloth or products such as Zogics Wipes. Plastic laminate and phenolic lockers can be cleaned similarly. Please use glass cleaner on glass lockers to avoid streaks. For wood veneer locker doors, Pledge or a similar product can be used. Caution should be used around locks or other hardware to keep them clear of polishes and chemicals so that they do not become discolored or over-saturated.